

COOLING CAPACITY: 18 WATTS/°F
 DIMENSIONS: 35.18"H X 10.68"W X 5.13"D
 WEIGHT: 37 LBS.
 MAXIMUM AMPS: 2.80/3.10 @ 120/110VAC 60/50HZ
 MAXIMUM AMPS: .96/1.06 @ 230/220VAC 60/50HZ
 MAXIMUM AMPS: 3.24 @ 48VDC

IQ2200HE-CF
TOP VIEW

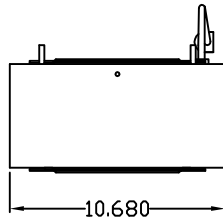

IQ2200HE-CF
LEFT SIDE

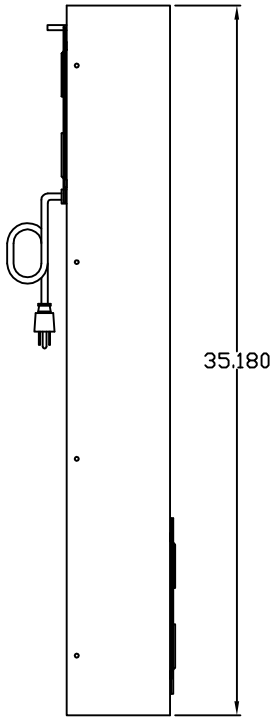

IQ2200HE-CF
FRONT VIEW

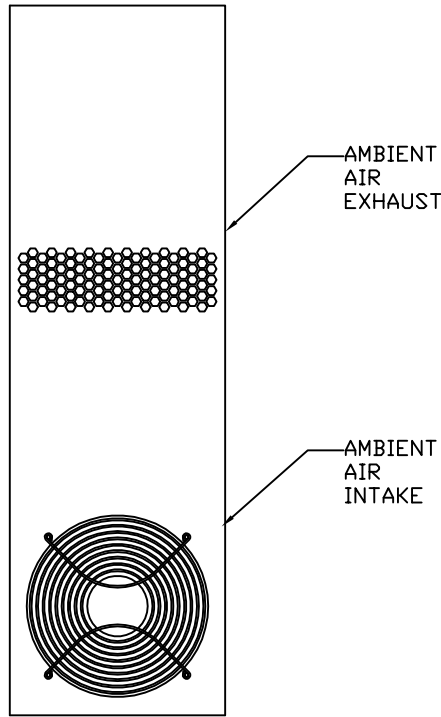

IQ2200HE-CF
RIGHT SIDE

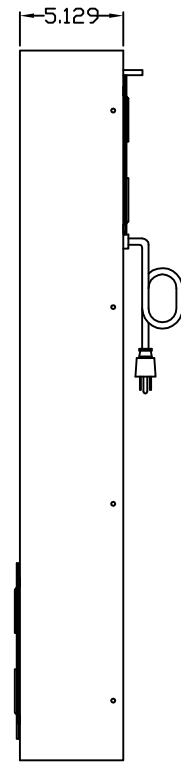

IQ2200HE-CF
BOTTOM VIEW

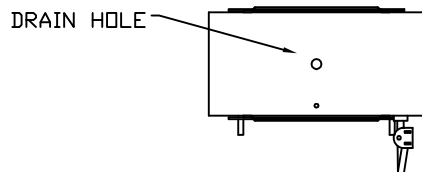

IQ2200HE-CF
REAR VIEW

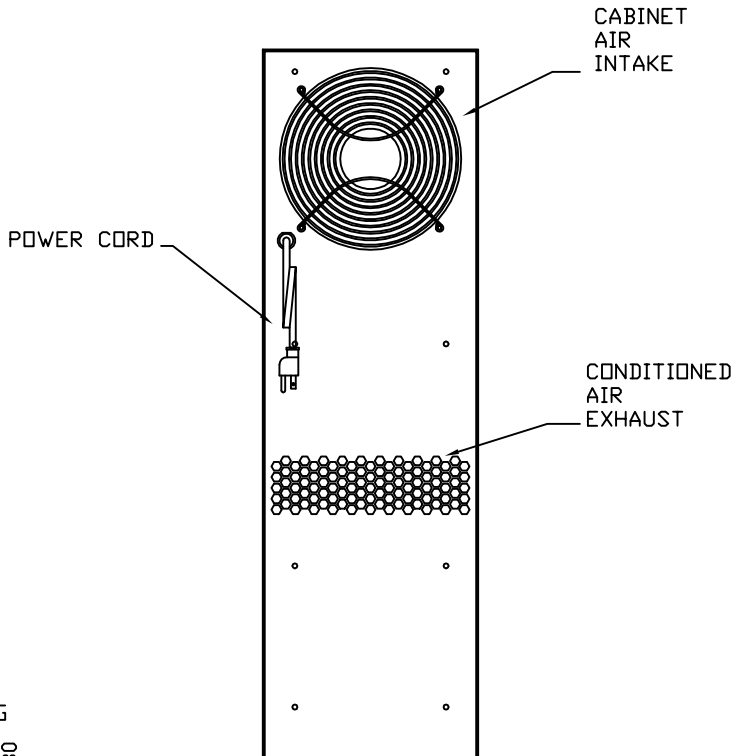

IQ2200HE-CF
CUT OUT DRAWING

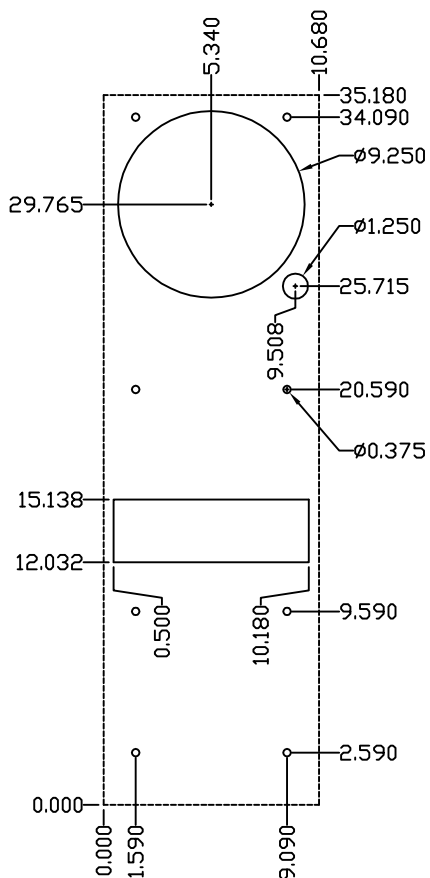

IQ2200HE-CF
GASKET DRAWING

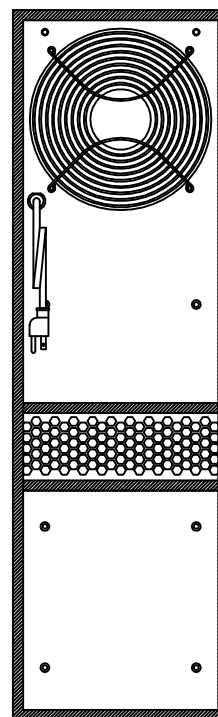

IMPORTANT
GASKET MUST BE
APPLIED AS SHOWN
FOR PROPER OPERATION
AND TO MAINTAIN
NEMA INTEGRITY.

0	INITIAL RELEASE	4-9-09	JMH
REV	DESCRIPTION	DATE	CHECKED
	REVISIONS		

PROPRIETARY DRAWING	DATE	REV	BY
	4-9-09		JMH
SHEET 2 OF 2			

	McQuay-Neuberger 14 YEARS SERVICE REPUTATION FOR QUALITY 784-887-8888 • 1-800-822-8888 WWW.MCQUAY-NEUBERGER.COM
IQ2200HE-CF	
IQ290909	0