

IQ8000T
 COOLING CAPACITY: 8000 BTUH (2346W) @131°F (55°C)
 MAXIMUM AMPS: 12.2 (1464W) @120V/60HZ
 MAXIMUM AMPS: 5.7/5.7 (1311/1254W) @230/220V 60/50HZ
 MAXIMUM OPERATING TEMP: 131°F (55°C)
 MINIMUM OPERATING TEMP: -4°F (-20°C)
 DIMENSIONS: 15.06" (383MM) H X 19.94" (507MM) W X 20.06" (510MM) D
 WEIGHT: 112 LBS (50.9KG)

REV	REVISION	CHG	DATE	APP	DATE	CN #
D	CHANGED THERMOSTAT DIMENSIONS	NAT	2/26/2021			ECN-1434
C	ADDED CFM, dBA, AND CLEARANCE INFO	RCC	3/23/2018			1351
B	ADDED WATTAGE INFO	RCC	12/29/2017			
A	REDRAWN IN SW	RCC	4/18/2017			

ITEM NUMBER	N/A	USED ON	IQ8000T
MATERIAL	N/A		
EST WT:	lbs		
DRAWN BY	RCC	DATE	4/18/2017
		SCALE	1:9

UNLESS OTHERWISE SPECIFIED TOLERANCES	
.X	±.060
.XX	±.030
.XXX	±.015
FRACTIONAL	±1/16
ANGULAR	±1/2°
SURFACE FINISH $\sqrt{63}$	
DO NOT SCALE DRAWING DIMENSIONS ARE INCHES	

ICE QUBE, INC.
THIS IS A PROPRIETARY DOCUMENT. DO NOT REPRODUCE OR DISCLOSE WITHOUT THE EXPRESS WRITTEN PERMISSION OF ICE QUBE, INC.
 DESCRIPTION
IQ8000T SPEC DRAWING XP2
 DRAWING NUMBER
IQ351445
 REV
D

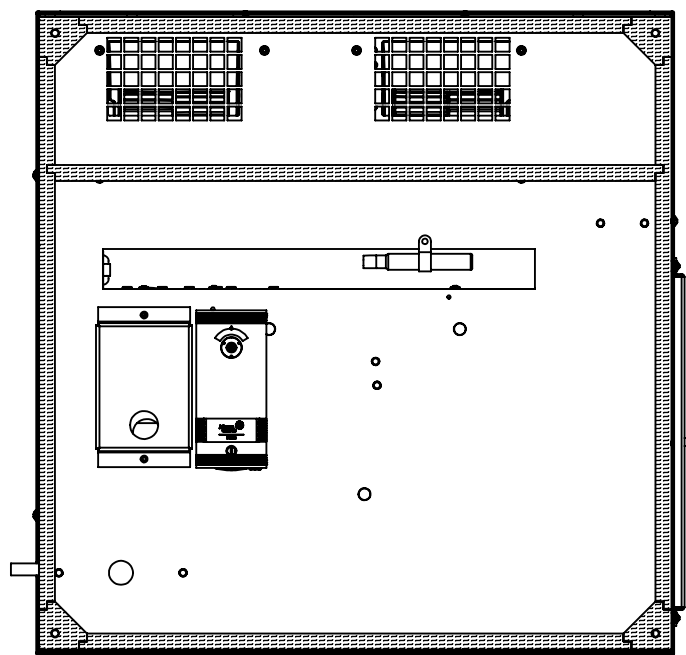
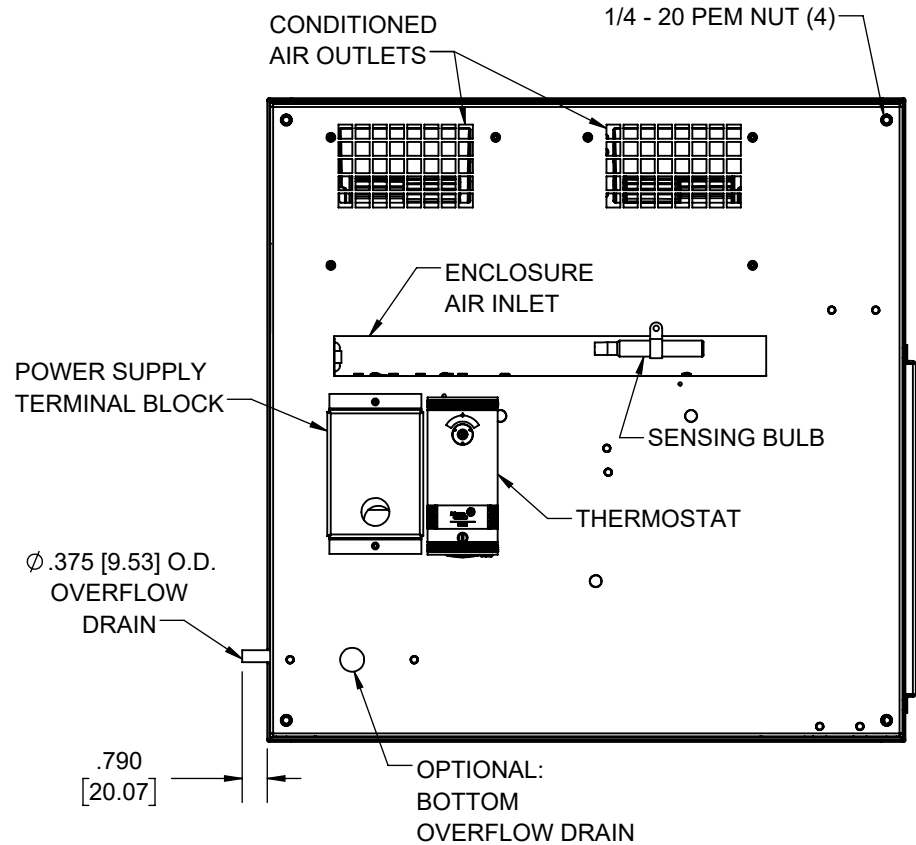

IMPORTANT
 GASKET MUST BE
 APPLIED AS SHOWN
 FOR PROPER OPERATION
 AND TO MAINTAIN
 NEMA INTEGRITY.

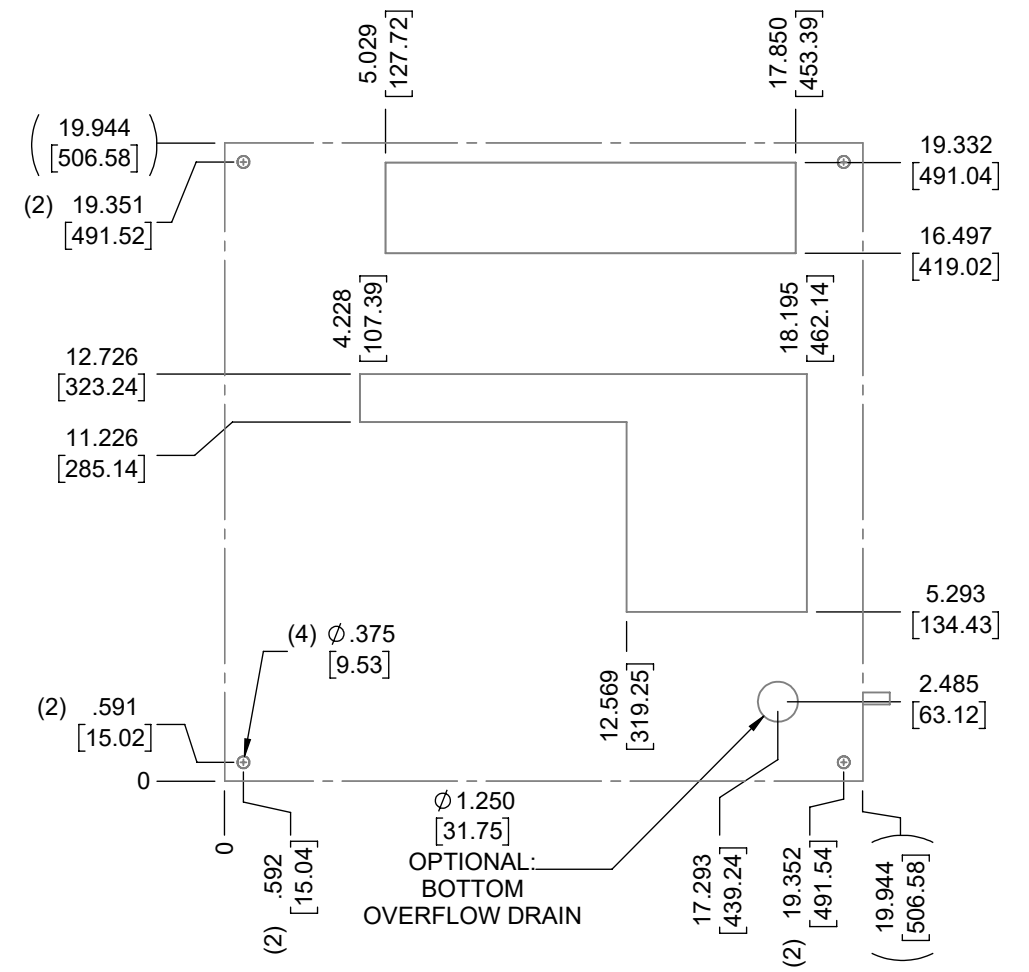

EVAP. OUTLET ≈ 410 CFM
 COND. OUTLET ≈ 410 CFM
 SOUND LEVEL @5FT FROM UNIT @ A HT. OF 3FT = 62 dBA
 SOUND LEVEL @2FT FROM UNIT @ A HT. OF 5FT = 63 dBA
 CONDENSER INLET MIN. CLEARANCE 3.05"

ITEM NUMBER N/A	USED ON IQ8000T	UNLESS OTHERWISE SPECIFIED TOLERANCES X ±.060 .XX ±.030 .XXX ±.015 FRACTIONAL ±1/4 ANGULAR ±1/2°	THIS IS A PROPRIETARY DOCUMENT. DO NOT REPRODUCE OR DISCLOSE WITHOUT THE EXPRESS WRITTEN PERMISSION OF ICE QUBE, INC. DESCRIPTION IQ8000T SPEC DRAWING XP2
MATERIAL N/A		SURFACE FINISH 63	
EST WT: lbs	DATE 4/18/2017	SCALE 1:6	DRAWING NUMBER IQ351445
DRAWN BY RCC			REV D