

STEP 1

ENSURE UNIT GASKET IS APPLIED PROPERLY.
MOUNT CONVERSION COLLAR TO UNIT AS SHOWN USING PROVIDED HARDWARE.
COMPRESS THE UNIT GASKET TO HALF OF ITS THICKNESS.

STEP 2

APPLY CONVERSION COLLAR GASKET AS SHOWN.
NOTE: UNIT HIDDEN FOR CLARITY

STEP 3

MOUNT UNIT AND CONVERSION COLLAR TO ENCLOSURE AS SHOWN
USING PROVIDED HARDWARE.
COMPRESS THE CONVERSION COLLAR GASKET TO HALF OF ITS THICKNESS.

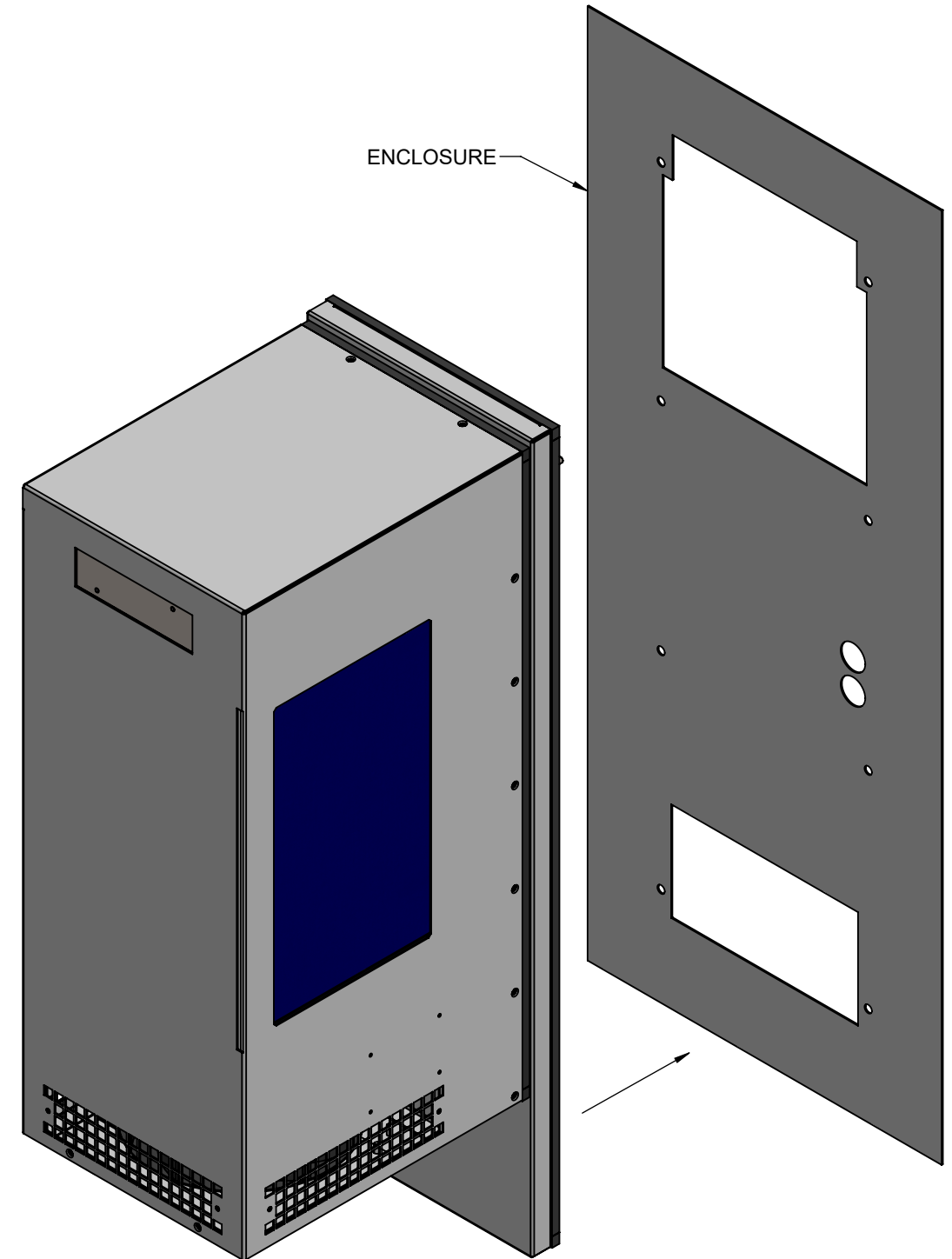
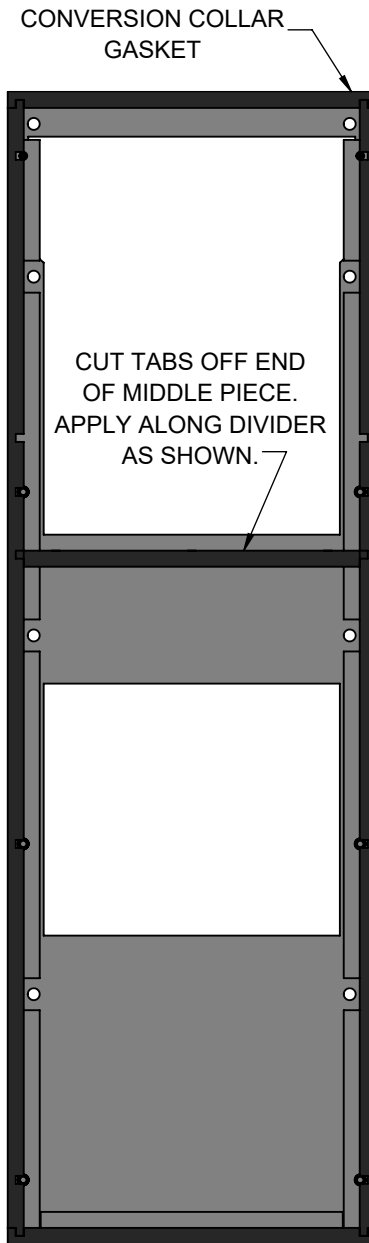
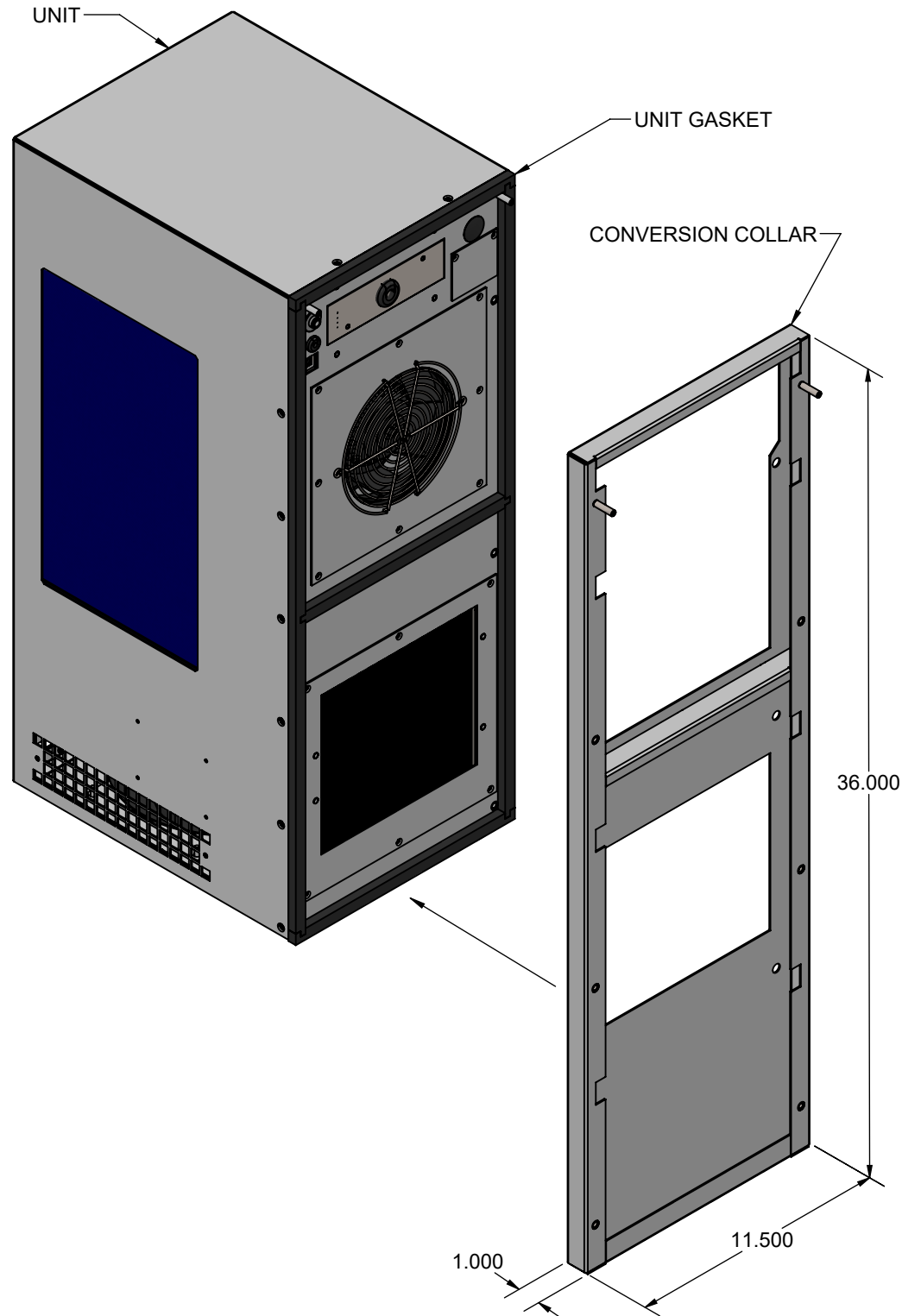

A	INITIAL DRAFT	NAT	7/30/2021				
REV	REVISION	CHG	DATE	APP	DATE	CN #	

ITEM NUMBER	N/A	USED ON	IQ4-5-6000VXS TO IQ4-5-6000EV AND IQ4-5-6000VXS TO IQ4-5-6000ECO
MATERIAL	N/A		
EST WT:	lbs		
DRAWN BY	NAT	DATE	7/30/2021
		SCALE	1:12

UNLESS OTHERWISE SPECIFIED TOLERANCES	
X	±.060
.XX	±.030
.XXX	±.015
FRACTIONAL	±1/16
ANGULAR	±1/2°
SURFACE FINISH	63
DO NOT SCALE DRAWING DIMENSIONS ARE INCHES	

ICE QUBE, INC.
THIS IS A PROPRIETARY DOCUMENT. DO NOT REPRODUCE OR DISCLOSE WITHOUT THE EXPRESS WRITTEN PERMISSION OF ICE QUBE, INC.

DESCRIPTION
IQ4-5-6000VXS TO IQ4-5-6000EV/ECO ADAPTER INSTRUCTIONS

DRAWING NUMBER
IQ352793

REV
A